



OWNERS AND SERVICE MANUAL

INNOVATIVE CONCEPTS IN ENTERTAINMENT INC.

10123 MAIN STREET, CLARENCE, NY 14031

SERVICE: 1-716-759-0360

FAX: 1-716-759-0884

E-MAIL: service@icegame.com

WEBSITE: www.icegame.com

TABLE OF CONTENTS

SAFETY & WARNINGS.....	PAGE 3 ~ 4
· BEFORE YOU BEGIN	
· INSTALLATION	
· WARNING	
GAME SETUP & FEATURES.....	PAGE 5 ~ 9
· GAME SETUP LOCATION	
· GETTING STARTED FOR THE FIRST TIME	
· GAME INSTRUCTIONS	
· GAME SETTING UP AND ADJUSTMENT	
· GAME SETTING UP	
· MODULATE VOLUME	
· MONITOR IMAGE ADJUSTMENT	
· ROCKER RESET	
· COIN METERS	
TROUBLESHOOTING.....	PAGE 10 ~ 11
MAINTENANCE / REPAIR.....	PAGE 12 ~ 16
· LIGHT BOX	
· MONITOR	
· CONTROL PANEL	
· HANDLE MECHANISM	
· HANDLE	
PARTS LISTING.....	PAGE 17
PINOUT CHART.....	PAGE 18 ~ 19
POWER SUPPLY.....	PAGE 20
WARRANTY INFORMATION.....	PAGE 21 ~ 22

SAFETY AND WARNINGS

BEFORE YOU BEGIN

Please take a moment to read this manual before turning on your “Chicken Coop” game for the first time.

WARNING: When installing this game, a grounded A.C. receptacle must be used. Failure to do so could result in injury to yourself or others. Failure to use a grounded receptacle could also cause improper game operation, or damage to the electronics.

Do not defeat or remove the grounding prong on the power cord for the same reason as given above. Using an improperly grounded game could void your warranty.

Have a qualified electrician check your A.C. receptacle to be sure the ground is functioning properly.

INSTALLATION

The game comes ready to play with just a few simple things to keep in mind.

1. Plug the power cord into an A.C. outlet and turn on power switch. The power switch for the game is located on the back lower middle side.

This game is designed to dissipate static electricity through the grounding plane of the game. If the A.C. Ground does not work, the game could discharge static electricity through the game circuitry, which could cause damage.

2. Make sure the game is level after installation. It is necessary to make sure the game is level for safety concerns.
3. Check that the A.C. voltage rating on the back of the game matches the A.C. voltage of your location.

The power supply is voltage auto-adjusted by itself (AC 100V ~ 240V, 6A, 50/60Hz). To operate the game at voltages other than those it was designed for. Please contact Our service department for voltage conversion information.

WARNING

DO NOT remove any of the components on the main board (e.g. compact flash and eproms) while the game is powered on. This may cause permanent damage to the parts and the main board. Removing any main board component part while powered on will void the warranty.

NOTE:

This game is intended for indoor use only.

On the back panel of the game: WARNING: Shock hazard – Do not open. Refer servicing to service personnel.

GAME SETUP AND FEATURES

Game Setup Location

The size shown on the diagram below will help you determine the area required for your game, and where you might want the game to be placed.

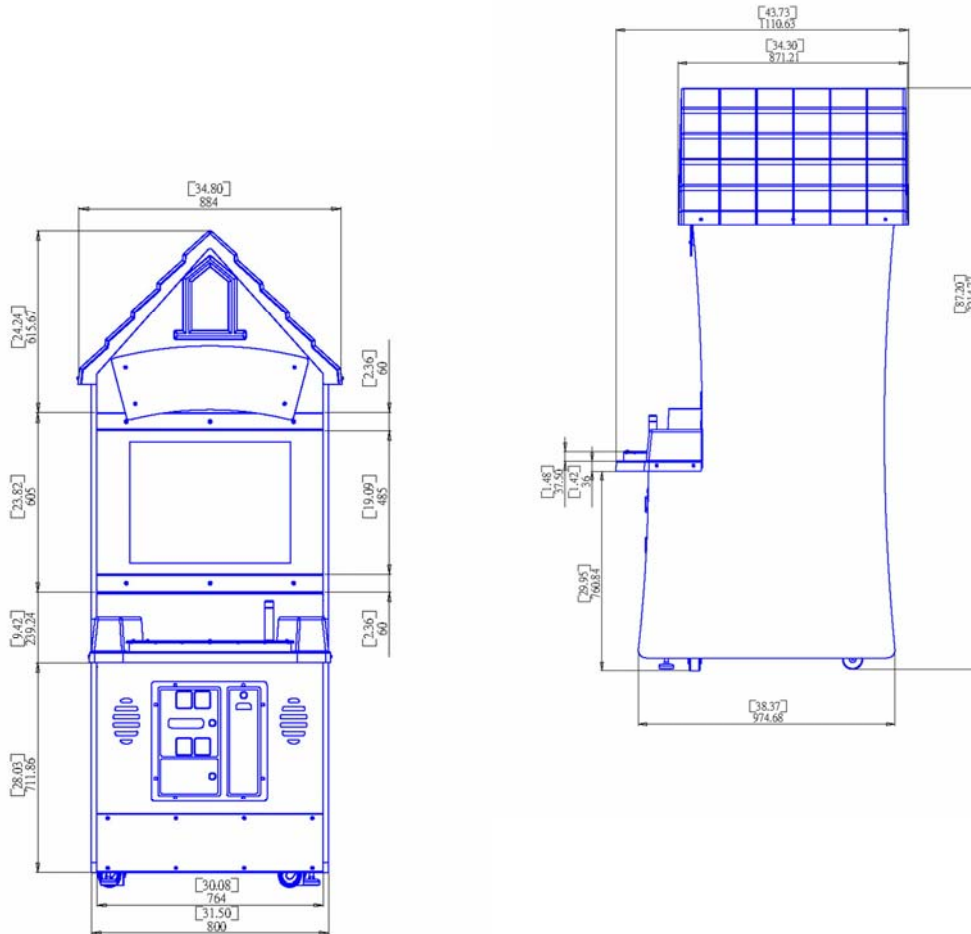

Getting Started for the First Time!

After removing the game from its carton, please make sure that the machine is placed on an even or level area. Do not raise or angle the machine. Move the machine with great care.

Plug the power cord into an AC outlet and turn on the power switch. The power switch is located on the back lower middle side. When the machine is powered on, the fluorescent light will light up and background music will start to play.

Check the "SETUP" screen to make sure that the machine is set up properly.

Load the machine with tickets.

Your new "Chicken Coop" is now ready to play!

Game Instructions

1. Insert coin(s) to play game.
2. Game starts as timer start to count down.
3. Control the joystick to play the game.
4. Try to collect as many eggs as you can to win points within the given time.
5. Scoring Table

Actions	Scores
Collect Golden Egg	3 Points
Collect Brown Egg	2 Points
Collect White Egg	1 Point
Collect Broken Egg	0 Point
Collect 2 X Score Bonus Egg	Double points won of remainder
Collect Time Bonus Egg	Extra play time of remainder

6. When timer return to 0, game is over and ticket(s) is rewarded according to total points scored.

Game Setting Up and Adjustment

Open the coin door, there are four buttons. Counting from the right side, first one **Menu** switch, second is **Select** button, third is **Set** button, and fourth is **Free Play** button.



1. Game Setting Up

Press Menu switch, enter Setup screen. Then press Select button to adjust cursor. Press Set button to adjust the setting.



□ COIN[S] / □ CREDIT[S]

Coin no. per credit

1 ~ 9 1 ~ 9

□ SCORE[S] / □ TICKET[S]

Score no. per ticket

1 ~ 10 1 ~ 9

GAME TIME □ **SECONDS**

Play time adjustment (5 sec. per interval)

30 ~ 80

EGG DIFFICULTY ADJUST □

Difficulty adjustment (the number is

2 ~ 5

bigger, the egg falling speed is faster)

MERCY TICKET SELECT □	Mercy ticket setting
0 ~ 9	
TICKET MAXIMUM □	Ticket Maximum setting
20~100	(5 pcs per interval) (5 pcs per interval)
TICKETS PAYOUT SELECT □	Ticket dispense setting
ON/OFF	
LANGUAGE SELECT □	Language Select
ENGLISH	

2. Modulate Volume

Press Menu switch to Modulate Volume screen. Press Set button to adjust volume.



Volume Value is 0 ~ 255

3. Monitor Image Adjustment

Press Menu switch to Monitor Image Adjustment screen. Use the image adjuster (inside the coin door) to adjust the image quality.



4. Rocker Reset

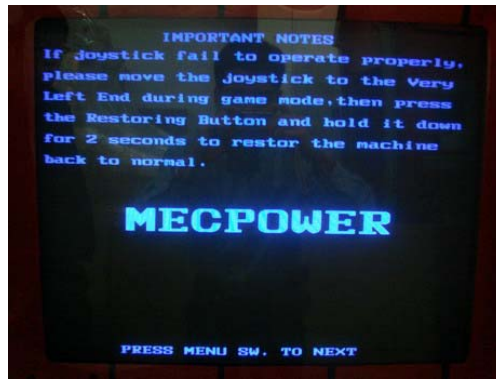

If joystick fails to operate properly, please move the joystick to the Very Left End during game mode, then press the restoring button (Rocker Reset) and hold it down for 2 seconds (2 –3 times) to restore the machine back to normal.



5. Coin Meters

The game has two electronic meters inside the coin door. The right meter will be increased by 1 each time a coin is dropped into the coin mechanisms. The left meter will be increased by 1 each time a ticket is dispensed.

TROUBLE SHOOTING

CAUTION

This game uses complex electronic components that are very sensitive to static electricity. Observe precautions below before handling these electronics. Failure to do so may void the warranty and damage electronic assemblies.

Before servicing electronics, turn off AC power to the game. Wait for capacitors to discharge.

DO NOT remove any of the components on the main board (e.g. compact flash and eproms) while the game is powered on. This may cause permanent damage to the parts and the main board.

Before touching or handling electronic assemblies, discharge static electricity on your body. To discharge this static, begin by connecting the line cord to a grounded outlet. Don't turn on the game. Next, touch the safety ground stud of the power supply chassis.

Store electronic assemblies in an anti-static area. Use anti-static bags to store or transport the game circuit boards.

Don't remove or connect electronic assemblies when cabinet power is on. Otherwise, you'll damage electronic assemblies and void the game's warranty.

After you complete maintenance or service, replace ground wires, shields, safety covers and install and tighten ground and mounting screw.

Video game monitors generate and store potentially high voltages. Avoid touching any part of the monitor until power has been off for some time. A picture tube can maintain a hazardous charge for up to several days. Only qualified technicians should service monitors.

Game Is Non-Functional

1	Verify that the game power switch is turned on.
2	Verify that earth ground is properly connected and all exposed metal points are properly grounded.
3	Verify that the line cord connector is firmly and correctly seated into the power entry module of AC power chassis.
4	Verify that correct AC line voltage is present at the outlet
5	Verify that the JAMMA wire harness connector is firmly and properly seated to the mating JAMMA PCB edge connector. DO NOT remove or install JAMMA connector when power is turned on. Doing so will damage the CPU assembly and void the warranty.
6	Verify that the DC power supply voltages at the game CPU assembly are set as follows. The following voltages should be set when the game CPU assembly is connected and the game is powered on. +5V: +4.9V - +5.1V /// +12V: +11.5V - +12.5V
7	Verify that the non-JAMMA connectors are attached at the proper location and are firmly seated.
8	Verify that the game DIP switches are set properly.
9	If game sounds can be heard but no picture is seen on the monitor, see monitor is non functional.

TROUBLE SHOOTING

Monitor Is Non-Functional

1	Verify the cabinet has AC line voltage present at the monitor and has earth ground connected.
2	Verify that the video is properly connected from the game boards output to the monitor input.
3	Verify that the monitor remote adjustment board is properly installed and connected to the monitor chassis. Verify that brightness and contrast are set above their minimum levels.
4	Check fuses on monitor chassis. Replace fuse or chassis as necessary.
5	Verify that the game is using a low-res monitor.

Sound Is Non-Functional

1	Verify the cabinet wiring is correct. Ensure that the speakers are properly connected to the audio wires from the JAMMA connector.
2	Verify that the power is providing: +5V: +4.9V - +5.1V +12V: +11.5V - +12.5V
3	Verify that the above listed voltages are present at the correct JAMMA connector pins.
4	Verify that the game volume has been turned up.

NOTE:

If joystick fails to operate properly, please move the joystick to the Very Left End during game mode, then press the restoring button (Rocker Reset) and hold it down for 2 seconds (2 –3 times) to restore the machine back to normal.

MAINTENANCE / REPAIR

1. Light Box



No.	Description	Qty
1	a9630-s4 VACUUM FORM ROOF	1
2	A9630-TR-03-LIGHT BOX-A	1
3	A9630-TK-02-MARQUEE	1
4	FCFTE36W8-BULB SOCKET	1
5	FCFTE36W8-FLUORENCE TUBE	1
6	BULB PLASTIC CLIP	1
7	1_4-3_4L-HEXAGON NUT	4
8	1_4X1inL-B-HEXAGON SCREW	4
9	#632X5_16-Zy-SCREW ROUND, CROSSED	3

2. Monitor

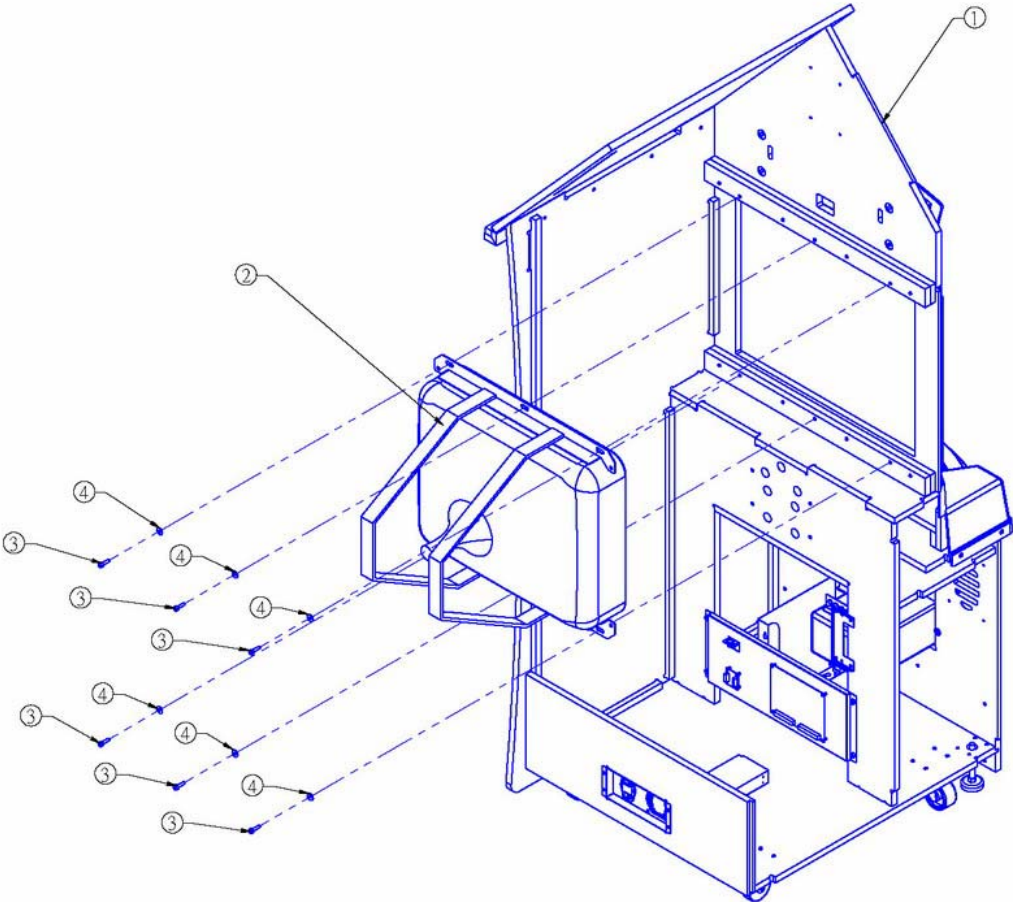

No.	Description	Qty
1	a9630-s1	1
2	CRT	1
3	1_4X1inL-B-HEXAGON SCREW	6
4	1_4-Zy-WASHER	6

3. Control Panel

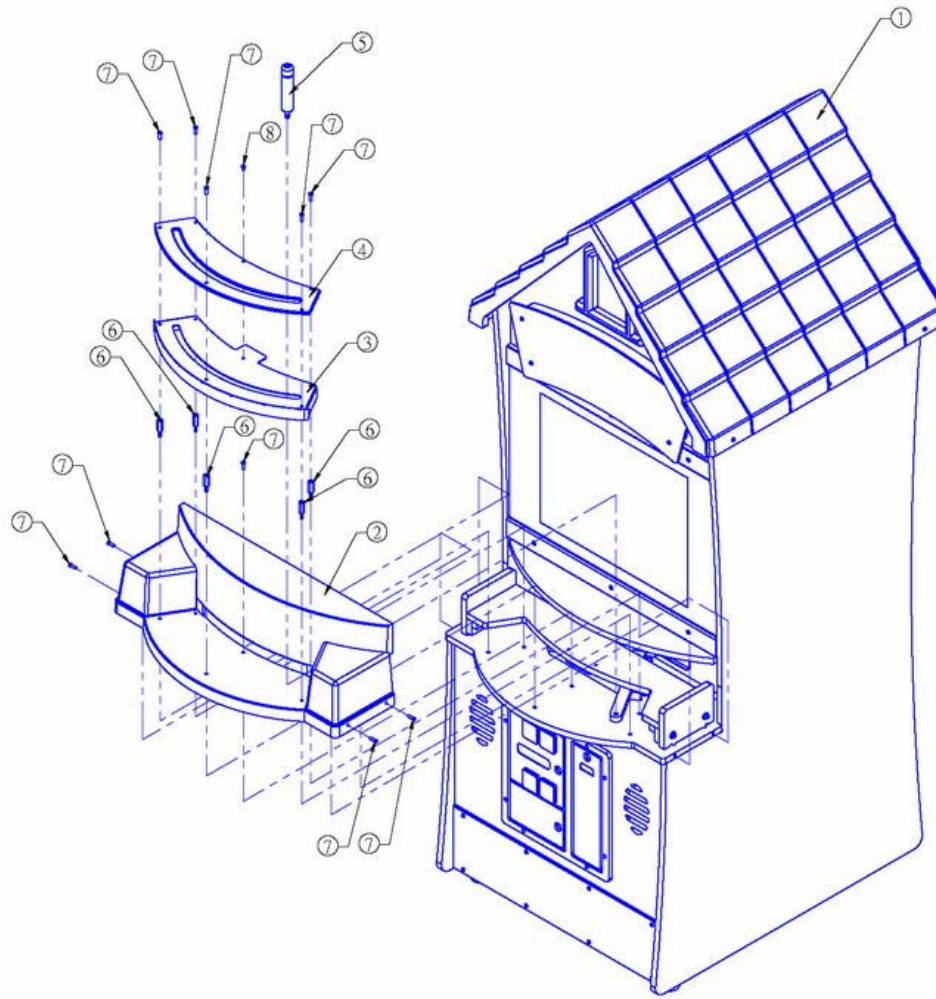

No.	Description	Qty
1	a9630-s2	1
2	A9630-TKP-01-Red Copped Front Cover Ass'y	1
3	A9630-TR-11-Metal Base Plate-A	1
4	A9630-TK-03-Plastic Panel	1
5	A9630-TP-04-handle Mechanism	1
6	A9630-TP-06-Post	5
7	1_4-3_4L-Hexagon Screw	10
8	1_4-3_8L-Hexagon Screw	1

4. Handle Mechanism

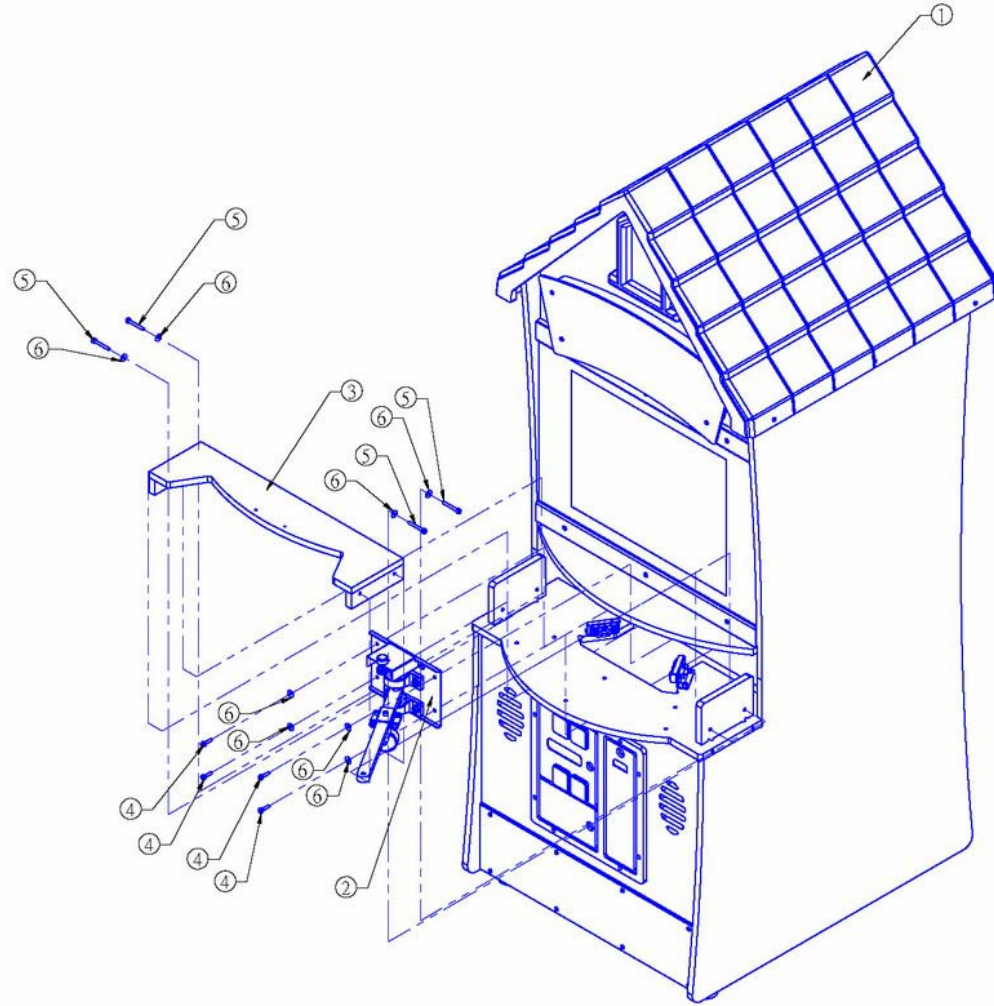

No.	Description	Qty
1	a9630-s3	1
2	A9630-Swing Ass'y	1
3	A9630-Wood Stand For Panel-M3-A	1
4	1_4X1inL-B-Hexagon Screw	4
5	1_4X2inL-B-Hexagon Screw	4
6	1_4-Zy-Washer	8

5. Handle

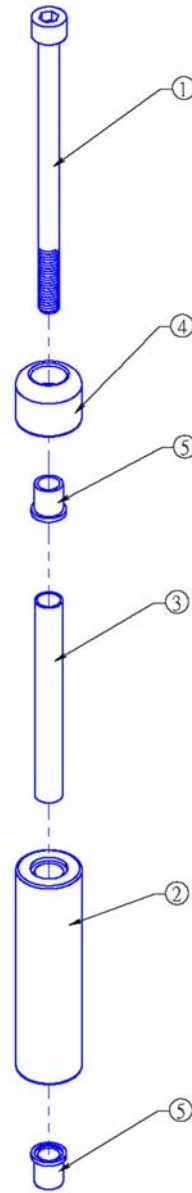

No.	Discription	Q'ty
1	3_8X6inL-B-Hexagon	1
2	A9630-TP-04-handle Rod-1	1
3	A9630-TP-02-Contour Pillar	1
4	A9630-TP-05-Handle Cover-1	1
5	A9630-TP-09-Sleeve	2

PARTS LISTING

P-CHC-01	CPU Board
P-CHC-02	VR
P-CHC-03	Fluoresce Lamp
P-CHC-04	Ballast
P-CHC-05	Handle w/swing Ass'y
P-CHC-05-1	Handle Ass'y
P-CHC-06	VR Control Board
P-CHC-07	Chassis PC Board
P-CHC-08	Speakers
P-CHC-09	Vacuum Form Door
P-CHC-10	Vacuum Form Roof
P-CHC-11	Yellow Cap
P-CHC-12	Decal Door
P-CHC-13	Catch Egg & Win Ticket
P-CHC-14	ICE Logo
P-CHC-16	Acrylic Control Panel
P-CHC-17	Front Door Decal
P-CHC-18	Left Decal
P-CHC-19	Right Decal
P-CHC-20	Kick Plate
P-CHC-21	Tempered Glass
P-CHC-22	VR Driving Gear
P-CHC-23	Handle
P-CHC-24	Power Supply
P-CHC-25	Menu setting Button w/2 meters
P-CHC-26	Menu Set Up Switch (Button)
P-CHC-27	Return Zero Switch

PINOUT CHART

CON1					
#	COLOR	SIGNAL	#	COLOR	SIGNAL
A1	BLK	GND	B1	RED	+5V
A2	YEL	+12V	B2		
A3			B3		
A4			B4		
A5	PNK	TICKET CONTROL SIGNAL	B5		
A6			B6	BRN/WHT	COIN COUNTER
A7			B7		
A8			B8		
A9			B9		
A10			B10		
A11	BLU/RED	TICKET COUNTER	B11		
A12			B12		
A13			B13		
A14	YEL/GRN	A/D BOARD (/RD SIGNAL) (ROCKER)	B14		
A15	RED/WHT	A/D BOARD (/WR SIGNAL) (ROCKER)	B15		
A16	BLU/GRY	A/D BOARD (/CS SIGNAL) (ROCKER)	B16		
A17			B17		
A18			B18	YEL/WHT	SPEAKER OUT SIGNAL (+)
A19			B19	YEL	+12V
A20	RED	+5V	B20	BLK	SPEAKER OUT GND (-)

PINOUT CHART

CON5					
#	COLOR	SIGNAL	#	COLOR	SIGNAL
A1	BLK	GND	B1	BLK	GND
A2	RED	+5V	B2	RED	+5V
A3			B3		
A4			B4		
A5	BLU/RED	COIN SWITCH	B5	BRN/WHT	MENU SWITCH
A6	GRY	FREE PLAY BUTTON	B6		
A7	RED/WHT	SELECT BUTTON	B7		
A8	YEL/GRN	TICKET FEEDBACK SIGNAL	B8	BLK	DATA SIGNAL 0 (ROCKER)
A9			B9		
A10	BLU	DATA SIGNAL 6 (ROCKER)	B10	GRN	DATA SIGNAL 5 (ROCKER)
A11	PNK	A/D CONVERSION OVER SIGNAL (INTR) (ROCKER)	B11		
A12			B12	PUR	DATA SIGNAL 7 (ROCKER)
A13	ORG	DATA SIGNAL 3 (ROCKER)	B13	YEL/WHT	SET BUTTON
A14	BLU/GRY	RESET BUTTON OF (ROCKER)	B14	BRN	DATA SIGNAL 1 (ROCKER)
A15	RED	DATA SIGNAL 2 (ROCKER)	B15	YEL	DATA SIGNAL 4 (ROCKER)
A16			B16		
A17			B17		
A18			B18		
A19	RED	+5V	B19	RED	+5V
A20	BLK	GND	B20	BLK	GND

POWER SUPPLY

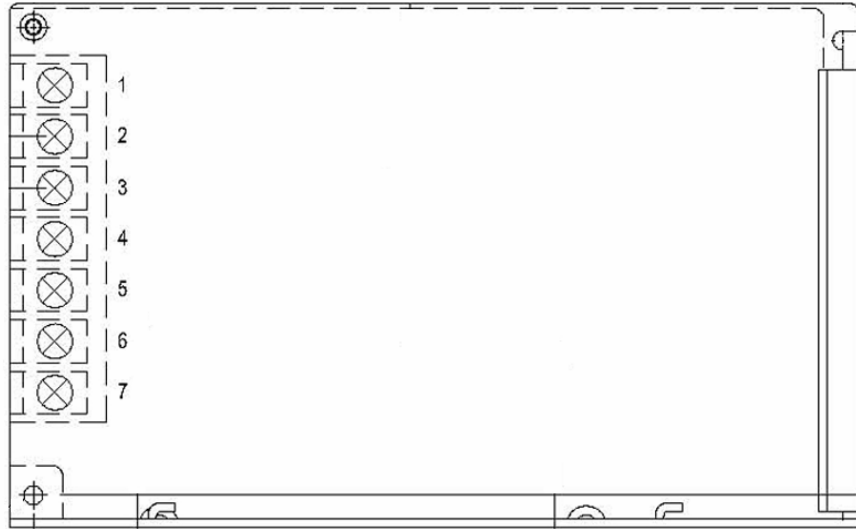

Pin No.	Assignment	Pin No.	Assignment	Pin No.	Assignment
1	AC/L	4	NOT USE	7	DC OUTPUT +5V
2	AC/N	5	DC OUTPUT +12V		
3	FG	6	DC OUTPUT COM		

NOTE:

The power supply is voltage auto-adjusted by itself (AC 100V ~ 240V, 6A, 50/60Hz).
 To operate the game at voltages other than those it was designed for. Please contact
 Our service department for voltage conversion information.

WARRANTY

I.C.E warrants all components in the CHICKEN COOP game to be free of defects in materials and workmanship for a period of ninety days from the date of purchase.

This warranty does not cover items damaged due to normal wear and tear, subjected to abuse, improperly assembled by the end user, modified, repaired, or operated in a fashion other than that described in the service manual.

If your CHICKEN COOP game fails to conform to the above-mentioned warranty, I.C.E.'s sole responsibility shall be at its option to repair or replace any defective component with a new or remanufactured component of equal to or greater O.E.M specification.

I.C.E. will assume no liability whatsoever, for costs associated with labor to replace defective parts, or travel time associated therein.

I.C.E.'s obligation will be to ship free of charge, replacement parts by U.P.S. Ground, U.S. mail, or other comparable shipping means. Any express mail or overnight shipping expense is at the cost of the purchaser.

Products will be covered under warranty only when :

- The serial number of the game with the defective parts is given. A tech number has been issued by an I.C.E. technical representative.
- The serial number of the defective part, if applicable, is given.
- Defective parts are returned to I.C.E., shipping pre-paid, in a timely fashion, if requested by I.C.E.
- A copy of the sales receipt is available as proof of purchase upon request of I.C.E.

I.C.E. distributors are independent, privately owned and operated. In their judgment, they may sell parts or accessories other than those manufactured by I.C.E. We cannot be responsible for the quality, suitability, or safety of any non-I.C.E. part, or any modification, including labor, which is performed by such a distributor.



WARRANTY

ICE Inc warrants that all of its products will be free from defects in material and workmanship.

When placing a warranty request, please be prepared to provide the following information:

- Serial Number of Game or Bill of Sale
- Machine Type
- A Detailed Description of the Equipment Fault Symptoms

ICE product, including Cromptons, Sam's Billiards, Uniana and Bell Fruit is warranted as follows:

- 180 days on the Main PCB and Computers
- 180 days on monitors
- 90 days on all other components (i.e. DBV's, Ticket Dispensers, sensors, etc).

ICE Inc shall not be obligated to furnish a warranty request under the following conditions:

- Equipment has been subjected to unwarranted stress through abuse or neglect
- Equipment has been damaged as a result of arbitrary repair/modification attempts
- Equipment that has failed through normal wear and tear

ICE Inc will assume no liability whatsoever for costs associated with labor to replace defective parts or travel time associated therein.

All defective warranty covered components will be replaced with new or factory refurbished components equal to OEM specifications. ICE Inc will cover all UPS ground, or comparable shipping means, freight costs during the warranty period. Expedited shipments are available for an additional charge.

Defective parts are returned to ICE Inc, at the customer's expense, in a timely fashion.

ICE distributors are independent, privately owned and operated. In their judgment, they may sell parts and/or accessories other than those manufactured by ICE Inc. We cannot be responsible for the quality, suitability or safety of any non-ICE part, modification (including labor) that is performed by such a distributor.

I.C.E. Parts/Service Dept.
Innovative Concepts in Entertainment
10123 Main St.
Clarence, NY 14031
Phone #: (716) - 759 – 0360
Fax #: (716) – 759 – 0884